

MULSANNE C/XC/XRC AND A340 SPEC SUB-FRAME CONVERSION KIT FITTING INSTRUCTIONS

C120 TYPE SUB-FRAMES

**ELISE S2 (post VIN:72400), ELISE 111R (post VIN:32403),
ELISE FEDERAL (std), EXIGE 2 (post VIN82395).**



Mulsanne C



XC



XRC

INTRODUCTION

Mulsanne C/ XC/ XRC are twin skin carbon seats developed for applications where light weight and extreme stiffness are of priority, both the front and back of the seats have a high quality Auto-clave moulded gloss finish.

These performance seat's have been specifically developed for the Lotus Elise S1/S2/111R/Federal, Exige S1/S2, 340R and VX/VXR220 range of cars with tailored fitting kits to suit each model (when ordering you should state Lotus/Vauxhall model and chassis VIN no). Due to the compact dimensions of the seat's they have also proven to be an ideal fitment to vehicles with limited cockpit space.

**WARNING, MOTORSPORT OR DRIVING CAN BE DANGEROUS
RESULTING IN DEATH OR PERSONAL INJURY.**

READ OUR FITTING INSTRUCTIONS CAREFULLY

This article is sold without warranty expressed or implied. No warranty or representation is made as to this product's ability to protect the user from injury or death. The user assumes that risk. The effectiveness, warranty and longevity of this equipment are directly related to the manner in which it is INSTALLED, USED, and/or MAINTAINED. THE USER ASSUMES THE RISK. Fitment of REVERIE PRODUCTS TO AUTOMOBILES THAT ARE SUBJECT TO A MANUFACTURER'S WARRANTY MAY VOID THE MANUFACTURER'S WARRANTY AND THE VEHICLES ABILITY TO MEET EMISSION OR OTHER TRANSPORT REGULATIONS.

By purchasing this product and opening the packaging, purchasers expressly acknowledge, understand and agree that they take , select and purchase these REVERIE products from REVERIE, its affiliates, distributors, and agents (collectively, REVERIE) "as is" and "with all faults".

The entire risk as to the quality and performance of these REVERIE parts is with the purchasers. Should the goods prove defective following their purchase; the purchasers assume the entire cost for all necessary servicing or repair or any resulting liability. Working on your car can be a dangerous activity. If you are unsure of what you are doing, please leave mechanical or Safety critical work to a skilled mechanic.

We take no responsibility for the incorrect use and / or installation of REVERIE products.

WWW.REVERIE.LTD.UK

INDEX

PAGE

3	UV-PROTECTION
3	PART NUMBER IDENTIFICATION
4	C120 TYPE SUB-FRAME GENERAL INFORMATION
5	FITTING KIT CONTENTS
6	FITTING INSTRUCTIONS

UV-PROTECTION

Please Note Epoxy Pre-preg products are not UV stable. Texallium products are particularly liable and can yellow in only 2 – 6 weeks. The epoxy resin will 'yellow' with prolonged exposure to UV radiation and material strength properties will slowly deteriorate. We recommend exterior products or those exposed to constant UV are either colour painted or at least Lacquered. We use predominately 2K car lacquers of medium solids, the DBS range has been found very suitable, although people have had equally good results with Urethanes varnishes and epoxy clear coats.

The surface should be sanded with 180, 240 then 320 grit and a cleaning solvent used to remove grease or dirt prior to paint application. Several coats may be required (normally 3 to 4 light coats) to avoid pin-holing, common with painting composite products. Pin holes may be dubbed in carefully with a brush, then wet flatted for a final application of 3 thin coats. **Let air dry only**, you may stove the paint at 70'c once fully air dried.

PART NUMBER IDENTIFICATION

Reverie part numbers are in red eg **R01SI6002A**

Lotus part numbers are in green eg **A111V0012J**

C120 TYPE SUB-FRAME GENERAL INFORMATION

The C120 type adjustable drivers side sub frame can be used once fitted with the ReVerie A340 spec drivers side sub-frame conversion kit. The C120 type passenger side sub frame needs to be replaced with a Lotus A340 type passenger side sub frame. A full passenger side A340 sub-frame kit is available from ReVerie Ltd.

The owner should refer to the MSA blue book for the correct installation of harnesses for competition.

Part Numbers

ELISE S2 (post VIN:72400), ELISE 111R (post VIN:32403),

ELISE FEDERAL (std), EXIGE 2 (post VIN:82395).

RHD C120B0135F Adjustable driver's side

LHD C120B0136F Adjustable driver's side

RHD C120U0006F fixed passenger side

LHD C120U0005F fixed passenger side

C120 to A340 spec sub-frame conversion kits

Drivers side conversion kit

RHD R01SI0039A

LHD R01SI0053A

Passenger side 340R sub-frame kit

RHD R01SI0023A

LHD R01SI0025A



Drivers side conversion kit shown

FITTING KIT CONTENTS

MULSANNE C/XC/XRC AND A340 SPEC SUB-FRAME CONVERSION KIT TO C120 TYPE SUB-FRAMES

ELISE S2 (post VIN:72400), ELISE 111R (post VIN:32403),

ELISE FEDERAL (std), EXIGE 2 (post VIN:82395).

GREEN = FITTING KIT CONTENTS SUPPLIED BY ReVerie Ltd.

RED = RETAINED FROM OLD SEAT REMOVAL

Drivers side (double sheer conversion kit)

Rear

2 * Bolt Cap head M8 * 20mm (12.9 spec)

2 * Washer Penny M8

Anchor

2 * Bolt Lotus spec double sheer (long) 7/16 * 43mm (R01SI6037A)

2 * Spacer Lotus spec steel double sheer 7/16 (R01SI6047A)

Front

2 * Nuts M8

2 * Washers small OD M8

Sub-frame

1 * Outside double sheer bracket (RHD=R01SI6042A LHD=R01SI6054A)

1 * Inside double sheer bracket (RHD=R01SI6041A LHD=R01SI6052A)

1 * Front slotted cross member (R01SI6040A)

Passenger side (340R sub-frame kit)

Rear

2 * Bolt Cap head M8 * 20mm (12.9 spec)

2 * Washer Penny M8

2 * Spacer nylon 5mm (R01SI6048A)

Anchor

2 * Bolt Lotus spec double sheer (long) 7/16 * 43mm (R01SI6037A)

2 * Spacer Lotus spec steel double sheer 7/16 (R01SI6047A)

2 * Spacer nylon 5mm 7/16 (R01SI6049A)

Front

2 * Nuts M8

2 * Washers small OD M8

Subframe

1 * Sub-frame 340R spec static Passenger side (RHD=R01SI6035A LHD=R01SI6036A)

FITTING INSTRUCTIONS

LOTUS SEAT AND SUB-FRAME REMOVAL

- A. Remove existing seats and sub frames from car by undoing the four bolts per sub frame attaching sub frames to chassis (retain bolts).
- B. Remove the seats from the sub frames by undoing the six retaining bolts, 2*M8 bolts at the rear (discard), 2* Lotus spec shanked 7/16 seat belt bolt's (discard), spacer's (discard) and spring's (retain), 2* M8 nuts underneath front of seat (retain).

FITTING CARBON SEAT AND A340 SPEC BRKTS TO STD DRIVERS SIDE SUBFRAMES (HARNESSES AND STD SEATBELTS)

A.

Remove both rear brkt's and front cross brace from sub frame, retain all bolts and washers.

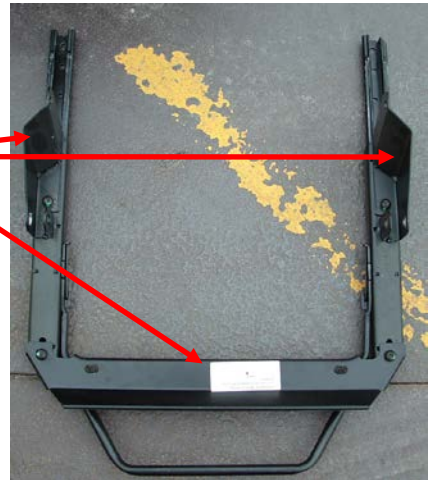

B.

With the std rear brkt's removed, loosely bolt (you will tighten them later) the double sheer A340 spec brkt's in place using the bolts and washers retained.

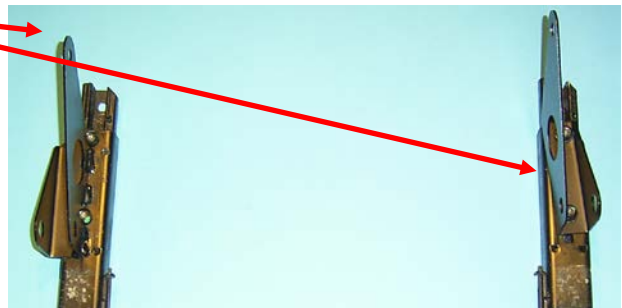

C.

Loosely bolt the A340 spec cross brace in the position shown noting which holes are used (RHD sub-frame shown, mirror fitment for LHD)



D.

Place the seat on the sub-frame and thread on the retained front M8 nuts and washers, leave loose for the moment to allow the seat a little float.

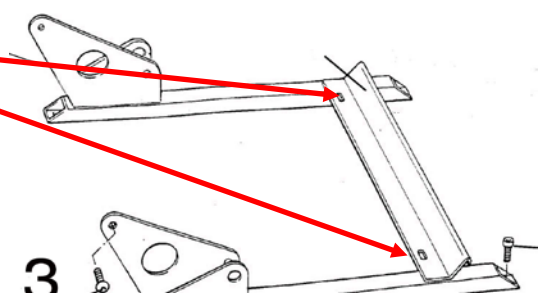

E.

Install the two provided 7/16 bolts and spacers, passing them through the nylon spacers (and seat belt eyes) and lightly threading them into the seat, leave loose for the moment to allow the seat a little float.

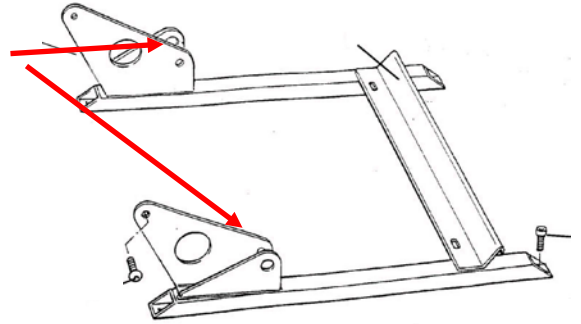

F.

Insert the two M8*20mm bolts and washers provided and tighten. The rest of the retaining bolts can now be tightened including the sub-frame out side brkt and cross brace.

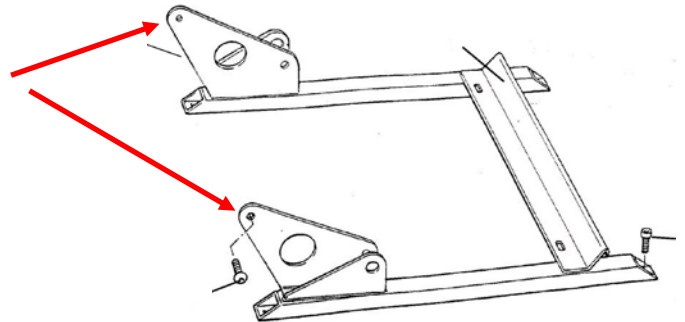

G.

If using OEM 340R harness belts ([A340U6005S](#)) a crutch strap is included the steel bar mounts under the sub frame and sits over the M8 studs under the front of the seat. If using another harness either 5 or 6 point than the straps should be taken through the seat and to a secure fixing on the chassis.



REINSTALLING SEAT AND SUB-FRAMES TO CHASSIS

The seats and sub-frames can now be reinstalled into the car, the drivers side should be bolted in loosely to the chassis and the seat ran back and for on the sub-frame runners several times until it runs smooth, the sub frame to chassis bolts can then be tightened. (See last page for mounting points)

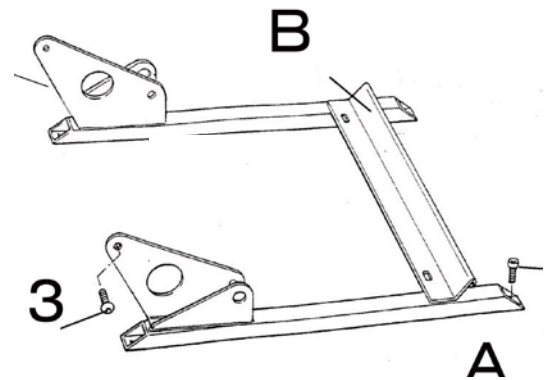

FITTING CARBON SEAT TO A340 SPEC PASSENGER SIDE SUB-FRAME (HARNESSES AND STD SEATBELTS)

A.

Loosely assemble the passenger sub-frame locate in the car using the 4 chassis mounting points. Then tighten all the sub-frame bolts to make it rigid and remove from the car.



B.

Place the seat on the sub-frame and thread on the retained front M8 nuts and washers, leave loose for the moment to allow the seat a little float.

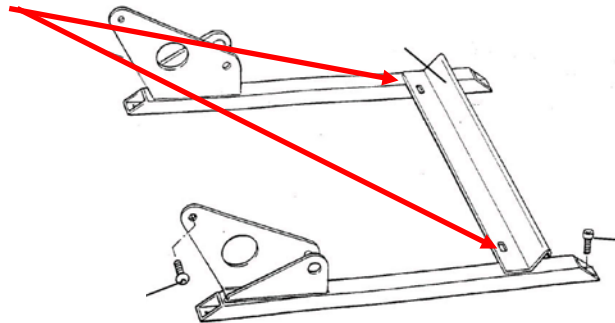

C.

Slide the 7/16 nylon packing spacers between the seat and sub frame then install the two provided 7/16 bolts and spacers (one spacer you will have retained earlier) passing them through the seat belt eyes and lightly threading them into the seat, leave loose for the moment to allow the seat a little float.

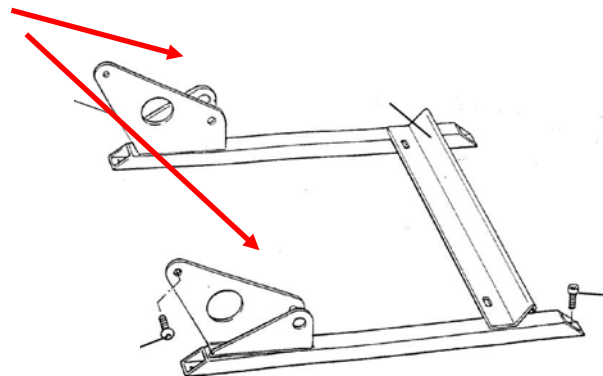

D.

Slide the M8 nylon spacers between the seat and sub frame and insert the two M8*20mm bolts and washers provided and tighten. The rest of the retaining bolts can now be tightened

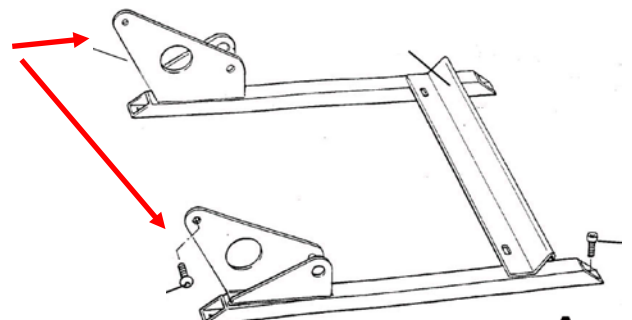

E.

If using OEM 340R harness belts (A340U6005S) a crutch strap is included, the steel bar mounts under the sub frame and sits over the M8 studs found under the front of the seat. If using another harness either 5 or 6 point then the straps should be taken through the seat and to a secure fixing on the chassis.



REINSTALLING SEAT AND SUB-FRAMES TO CHASSIS

The seats and sub-frames can now be reinstalled into the car, the passenger side can be bolted straight in.

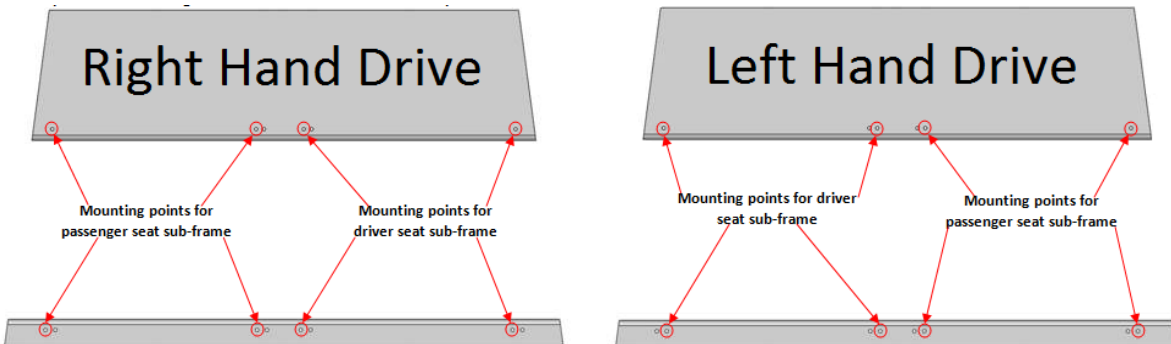

Pay close attention to which holes are used. (RHD shown, LHD is mirror fitment)

Drawing Views of Passenger Subframes:

RHD Vehicles

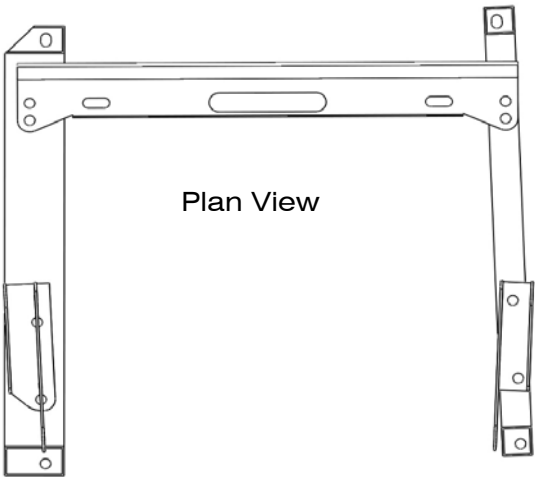
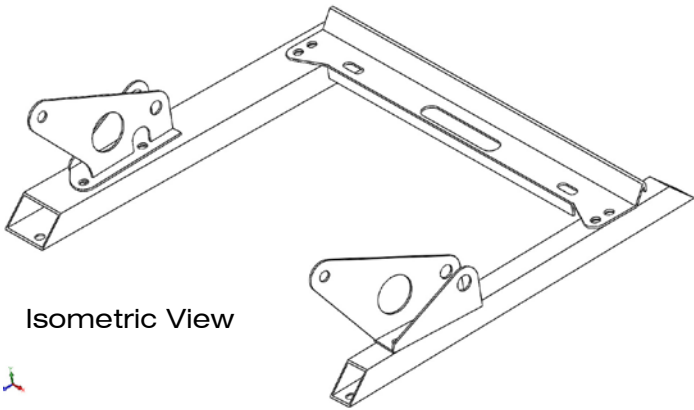

LHD Vehicles

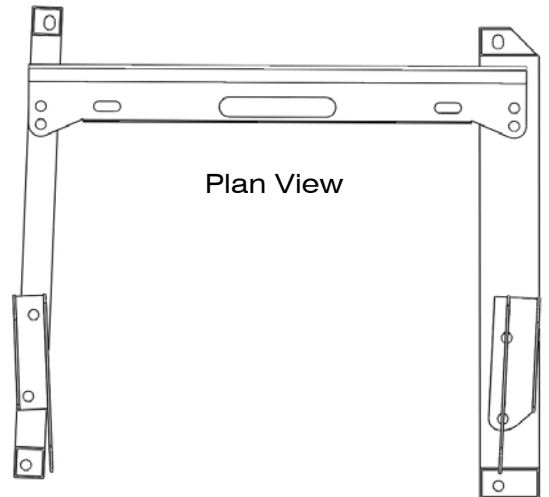
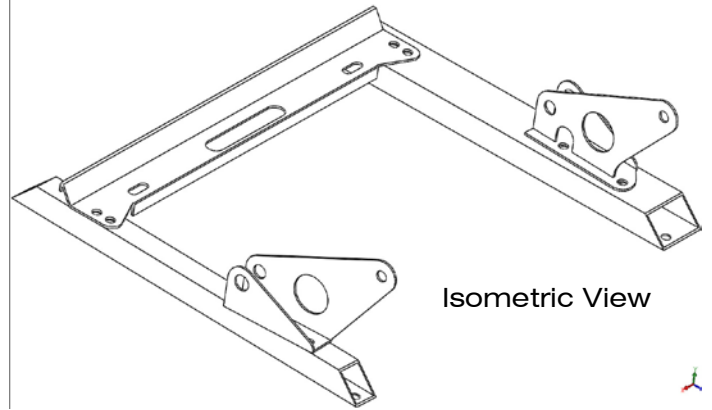

Drawing Views of Driver Subframes:

RHD Vehicles



LHD Vehicles

